



# Linear Ball Slide

THK General Catalog

## A Product Descriptions

<b>Features and Types</b> .....	A9-2
Features of the Linear Ball Slide .....	A9-2
• Structure and Features .....	A9-2
Types of the Linear Ball Slide .....	A9-4
• Types and Features .....	A9-4
<b>Point of Selection</b> .....	A9-5
Rated Load and Nominal Life .....	A9-5
Accuracy Standards .....	A9-7
<b>Dimensional Drawing, Dimensional Table</b>	
Model LSP .....	A9-8
Model LS .....	A9-10
Model LSC .....	A9-12
• Speed Controller .....	A9-14
• Dedicated Unit Base Model B .....	A9-14
• Limit Switch .....	A9-15
<b>Model No.</b> .....	A9-16
• Model Number Coding .....	A9-16
• Notes on Ordering .....	A9-17
<b>Precautions on Use</b> .....	A9-18

## B Support Book (Separate)

<b>Features and Types</b> .....	B9-2
Features of the Linear Ball Slide .....	B9-2
• Structure and Features .....	B9-2
Types of the Linear Ball Slide .....	B9-4
• Types and Features .....	B9-4
<b>Point of Selection</b> .....	B9-5
Rated Load and Nominal Life .....	B9-5
<b>Model No.</b> .....	B9-7
• Model Number Coding .....	B9-7
• Notes on Ordering .....	B9-8
<b>Precautions on Use</b> .....	B9-9

## Features of the Linear Ball Slide

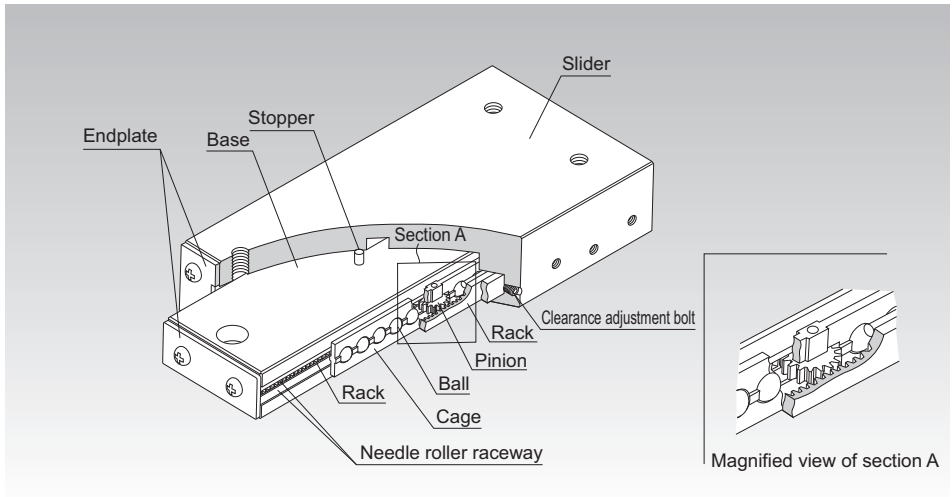

Fig.1 Structure of Linear Ball Slide Model LSP

### Structure and Features

The Linear Ball Slide is a highly corrosion resistant slide unit that has an extremely low friction coefficient because stainless steel balls roll on four stainless steel needle roller raceways that are hardened and ground.

In addition, model LSP has a pinion gear in the center and a rack on the base to prevent the cage from slipping.

A ball slide equipped with a cylinder model LSC has a cylinder for drive in the base to downsize the system and reduce the space and the weight.

Its components are all made of stainless steel, which is highly corrosion resistant. Furthermore, since its inertia is small, the slide system is highly responsive to high speed. By simply securing the Linear Ball Slide on the mounting surface, the user can easily achieve a linear guide mechanism. Thus, this slide system is optimal for locations requiring high accuracy, such as optic measuring machines, automatic recorders, small electronic-parts assembling machines, OA equipment and its peripherals.

#### [A Unit Type That Allows Easy Installation]

The clearance and motion of the slider is adjusted to the best state. Therefore, a highly accurate slide mechanism can be gained by simply mounting the unit on the flat-finished mounting surface.

#### [Lightweight and Compact]

A light aluminum alloy is used in the base and the slider to reduce the weight.

#### [Smooth Motion]

The balls and the raceway (needle roller raceway) are in point contact, which causes the smallest rolling loss, and the balls are evenly retained in the ball cage. This allows the slide system to perform rolling motion at a minimal coefficient of friction ( $\mu = 0.0006$  to  $0.0012$ ).

#### [Highly Corrosion Resistant]

The base and the slider are made of an aluminum alloy and their surfaces are treated with alumite (anodization processing), which is highly resistant to corrosion and wear.

The balls, needle roller raceways and screws are made of stainless steel, making the system highly corrosion resistant.

# Types of the Linear Ball Slide

## Types and Features

### Linear Ball Slide with a Rack Model LSP

Specification Table⇒ **A9-8**

With model LSP, the cage has a rack and pinion mechanism, thus to prevent the cage from slipping.

Also, since the cage does not slip even in vertical mount, this model is used in an even broader range of applications.

Note) Do not use the stopper as a mechanical stopper.

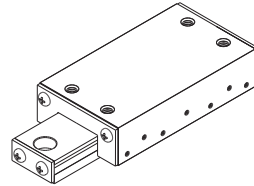

Model LSP

### Linear Ball Slide Model LS

Specification Table⇒ **A9-10**

Model LS is a unit-type linear system for finite motion that has a structure where balls are arranged between the base and the slider via a needle roller raceway.

It is incorporated with a stopper mechanism, thus to prevent damage deformation caused by collision between the cage and the endplate.

Note) Do not use the stopper as a mechanical stopper.

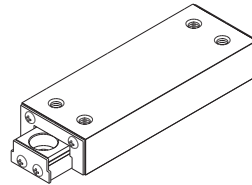

Model LS

### Linear Ball Slide with a Cylinder Model LSC

Specification Table⇒ **A9-12**

Model LSC contains an air cylinder for drive inside the base. Feeding air from the two ports on the side face of the base allows the slide to perform reciprocating motion. Since the cylinder is of double-acting type, horizontal traveling speed can be adjusted using the speed controller. The cylinder and the piston are made of a corrosion resistant aluminum alloy, and their surfaces are specially treated to increase wear resistance and durability. Additionally, the cage has a rack and pinion mechanism, thus enabling the cage to operate without slipping.

Air-feeding ports for piping are provided on one side face, ensuring a certain degree of operability and easy assembly even if the installation site has a limited space and is complex.

The table on the right shows the specifications of the air cylinder incorporated in model LSC.

Note) Do not use the stopper as a mechanical stopper.

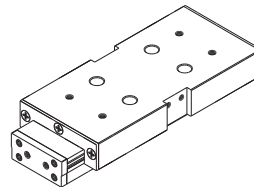

Model LSC

<Cylinder specifications>

Type of action	Double-acting
Fluid used	air (no lubrication)
Working pressure	100 kPa to 700 kPa (1 kgf/cm <sup>2</sup> to 7 kgf/cm <sup>2</sup> )
Stroke velocity	50 to 300mm/s

## Rated Load and Nominal Life

### [Rated Loads in All Directions]

The rated loads of models LS, LSP and LSC are identical in the vertical and horizontal directions.

### [Static Safety Factor $f_s$ ]

Linear Ball Slide models LS, LSP or LSC may receive an unexpected external force while it is stationary or operative due to the generation of an inertia caused by vibrations and impact or start and stop. It is necessary to consider a static safety factor against such a working load.

$$f_s = \frac{C_0}{P_c} \quad \text{or} \quad f_s = \frac{M_0}{M}$$

- $f_s$  : Static safety factor
- $C_0$  : Basic static load rating (N)
- $M_0$  : Static permissible moment (N-m)  
( $M_A, M_B$  and  $M_C$ )
- $P_c$  : Calculated load (N)
- $M$  : Calculated moment (N-m)

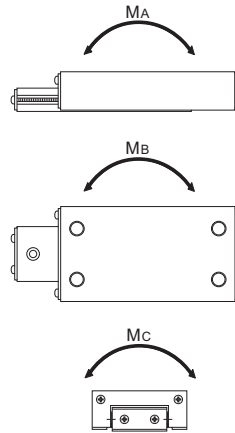

### ● Reference Value of Static Safety Factor

The static safety factors indicated in Table1 are the lower limits of reference values in the respective conditions.

Table1 Reference Value of Static Safety Factors ( $f_s$ )

Machine using the LM system	Load conditions	Lower limit of $f_s$
General industrial machinery	Without vibration or impact	1 to 1.3
	With vibration or impact	2 to 7

**[Nominal Life]**

The service life of the Linear Ball Slide is obtained using the following equation.

$$L = \left( \frac{1}{f_w} \cdot \frac{C}{P_c} \right)^3 \times 50$$

- L : Nominal life (km)  
(The total number of revolutions that 90% of a group of identical Linear Ball Slide units independently operating under the same conditions can achieve without showing flaking)
- C : Basic dynamic load rating (N)
- P<sub>c</sub> : Calculated load (N)
- f<sub>w</sub> : Load factor (see Table2)

**[Calculating the Service Life Time]**

When the nominal life (L) has been obtained, if the stroke length and the number of reciprocations per minute are constant, the service life time is obtained using the following equation.

$$L_h = \frac{L \times 10^6}{2 \times l_s \times n_1 \times 60}$$

- L<sub>h</sub> : Service life time (h)
- l<sub>s</sub> : Stroke length (mm)
- n<sub>1</sub> : Number of reciprocations per minute (min<sup>-1</sup>)

● **f<sub>w</sub>: Load Factor**

In general, reciprocating machines tend to involve vibrations or impact during operation. It is extremely difficult to accurately determine vibrations generated during high-speed operation and impact during frequent start and stop. Therefore, when the actual load applied on model VR or VB cannot be obtained, or when speed and vibrations have a significant influence, divide the basic load rating (C or C<sub>0</sub>), by the corresponding load factor in Table2 of empirically obtained data.

Table2 Load Factor (f<sub>w</sub>)

Vibrations/impact	Speed(V)	f <sub>w</sub>
Faint	Very low V ≤ 0.25m/s	1 to 1.2
Weak	Slow 0.25 < V ≤ 1m/s	1.2 to 1.5

## Accuracy Standards

The accuracies of Linear Ball Slide models LS, LSP and LSC are defined as follows.

Running parallelism of the top face of the slide  
: 0.010mm MAX/10mm

Positioning repeatability of the top face of the slide  
: 0.0015mm MAX

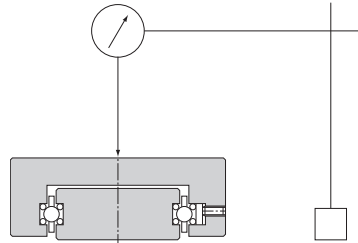
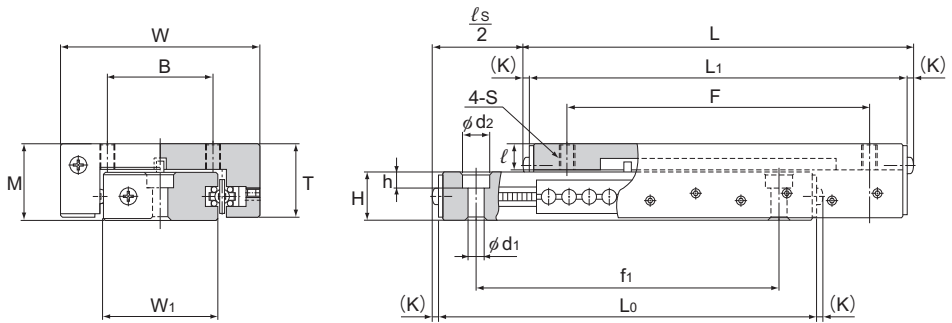
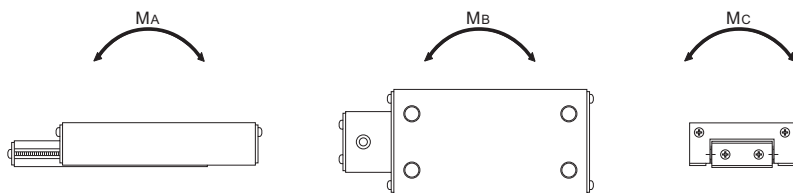

Fig.1 Accuracy Standards

# Model LSP



Model No.	Slider dimensions									
	Max. Stroke $\ell_s$	Height M $\pm 0.25$	Width W $\pm 0.25$	Length L	T	L <sub>1</sub>	(K)	B	F	S× $\ell$
LSP 1340	15	13	25	42	12.5	40	1	11	30	M3×5
LSP 1365	25	13	25	67	12.5	65	1	11	55	M3×5
LSP 1390	50	13	25	92	12.5	90	1	11	80	M3×5
LSP 2050	25	20	44	53	18.3	50	1.5	20	35	M5×8.2
LSP 2080	50	20	44	83	18.3	80	1.5	20	65	M5×8.2
LSP 20100	75	20	44	103	18.3	100	1.5	20	85	M5×8.2
LSP 25100	50	25	66	103.8	24	100	1.9	35	75	M5×8.5
LSP 25125	75	25	66	128.8	24	125	1.9	35	100	M5×8.5
LSP 25150	100	25	66	153.8	24	150	1.9	35	125	M5×8.5



Unit: mm

	Base dimensions					Static permissible moment*		Basic load rating		Mass g
	Width W <sub>1</sub>	Height H	d <sub>1</sub> ×d <sub>2</sub> ×h	Length L <sub>0</sub>	f <sub>1</sub>	M <sub>A</sub> , M <sub>B</sub> N-m	M <sub>C</sub> N-m	C N	C <sub>0</sub> N	
	12.2	7.7	3.3×6×3.3	40	30	0.88	0.49	68.6	118	
12.2	7.7	3.3×6×3.3	65	55	1.76	0.98	118	206	60	
12.2	7.7	3.3×6×3.3	90	80	3.04	1.27	157	275	85	
22.3	11	5.3×9×5.3	50	35	1.37	2.25	157	284	114	
22.3	11	5.3×9×5.3	80	65	3.53	4.51	304	559	184	
22.3	11	5.3×9×5.3	100	85	5	5.69	392	706	231	
38	15.8	5.3×9×5.3	100	75	9.22	14.5	588	1069	433	
38	15.8	5.3×9×5.3	125	100	12.9	18.1	735	1333	547	
38	15.8	5.3×9×5.3	150	125	17.5	21.9	882	1598	652	

Note) \*M<sub>A</sub>, M<sub>B</sub> and M<sub>C</sub> each indicate the permissible moment per LM system, as shown in the figure above.

# Model LS

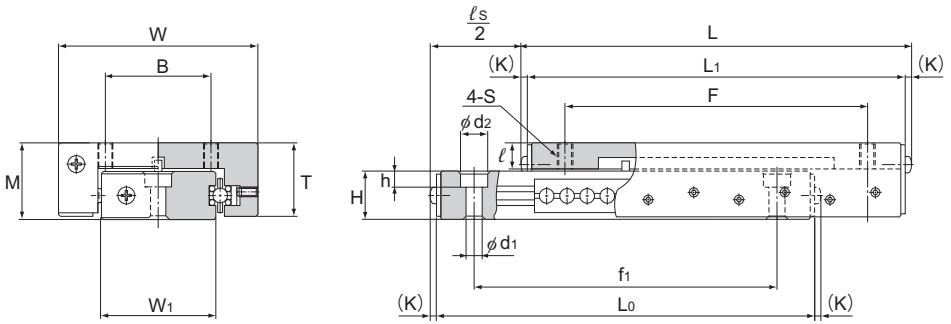

Model No.	Slider dimensions									
	Max. Stroke $\ell_s$	Height M $\pm 0.25$	Width W $\pm 0.25$	Length L	T	L <sub>1</sub>	(K)	B	F	S × $\ell$
LS 827	13	8	14.2	28.7	7.6	27	0.85	5.5	16	M2 × 3
LS 852	25	8	14.2	53.7	7.6	52	0.85	5.5	41	M2 × 3
LS 877	50	8	14.2	78.7	7.6	77	0.85	5.5	66	M2 × 3
LS 1027	13	10	19	28.7	9.2	27	0.85	8.5	16	M3 × 3.5
LS 1052	25	10	19	53.7	9.2	52	0.85	8.5	41	M3 × 3.5
LS 1077	50	10	19	78.7	9.2	77	0.85	8.5	66	M3 × 3.5

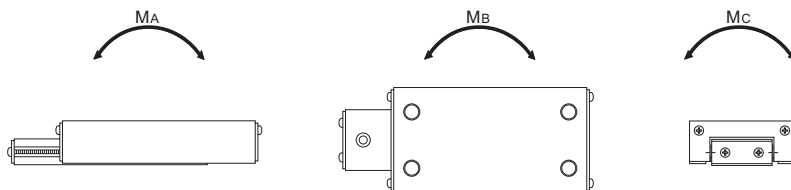

Unit: mm

	Base dimensions					Static permissible moment*		Basic load rating		Mass g
	Width $W_1$	Height H	$d_1 \times d_2 \times h$	Length $L_0$	$f_1$	$M_A, M_B$ N-m	$M_C$ N-m	C N	$C_0$ N	
	6.2	4.7	2.2×3.9×1.4	27	19	0.2	0.29	39.2	68.6	
6.2	4.7	2.2×3.9×1.4	52	35	0.49	0.39	68.6	118	15	
6.2	4.7	2.2×3.9×1.4	77	60	0.88	0.59	98	167	21	
9.6	6.2	3.3×6×3.1	27	19	0.29	0.59	58.8	108	13	
9.6	6.2	3.3×6×3.1	52	35	0.78	1.08	108	186	23	
9.6	6.2	3.3×6×3.1	77	60	1.47	1.57	157	275	34	

Note) \* $M_A$ ,  $M_B$  and  $M_C$  each indicate the permissible moment per LM system, as shown in the figure above.

# Model LSC

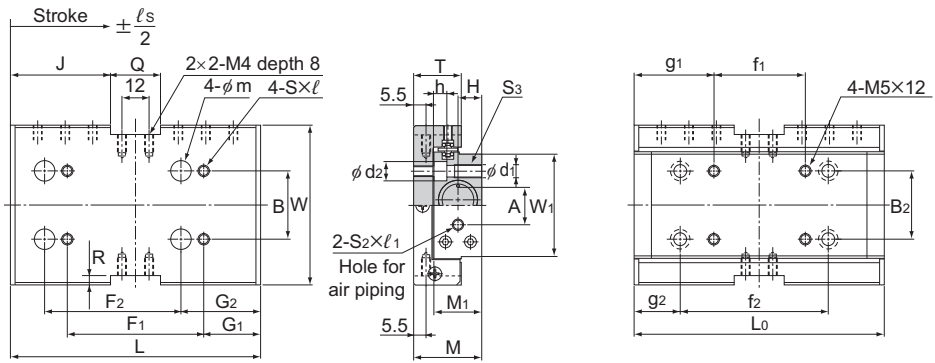

Model No.	Max. Stroke $\ell_s$ +0.5 0	Cylinder Inner diameter	Slider dimensions					
			Theoretical thrust (at 500 kPa) N	Height M $\pm 0.05$	Width W	L	T	B
LSC 1015	15	10	38.2	25	50	80	24	20
LSC 1515	15	15	86.3	30	70	80	21	30
LSC 1530	30	15	86.3	30	70	110	21	30
LSC 1550	50	15	86.3	30	70	150	21	30

Model No.	L <sub>0</sub>	B <sub>2</sub>	Base dimensions						
			f <sub>2</sub>	g <sub>2</sub>	f <sub>1</sub>	g <sub>1</sub>	d <sub>1</sub> ×d <sub>2</sub> ×h	A	S <sub>3</sub>
LSC 1015	80	20	40	20	—	—	3.3×5.5×3.5	13	M4
LSC 1515	80	30	40	21	23	29.5	5.2×9×5.5	17	M6
LSC 1530	110	30	60	25	40	35	5.2×9×5.5	17	M6
LSC 1550	150	30	100	25	78	36	5.2×9×5.5	17	M6

## Model number coding

**LSC1515 B S L**

Model number

With unit base

With external stopper

With limit switch

Note) Unit base, external stopper and limit switch are not available for model LSC1015.

The speed controller is optional.

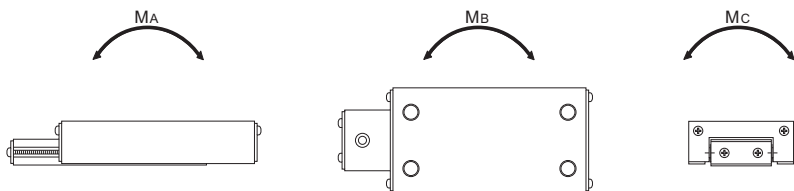

Unit: mm

Slider dimensions										
	F <sub>1</sub>	G <sub>1</sub>	S×l	m	G <sub>2</sub>	F <sub>2</sub>	J	Q	R	M <sub>1</sub>
	40	20	M4×7	5.5	12.5	40	—	—	—	16.5
	40	19	M5×8	9	28.5	40	29	22	4	21
	60	25	M5×8	9	35	60	44	22	4	21
	100	25	M5×8	9	50	50	64	22	4	21

Base dimensions			Static permissible moment*		Basic load rating		Mass kg
W <sub>1</sub>	H	S <sub>2</sub> ×l <sub>1</sub>	M <sub>A</sub> , M <sub>B</sub> N-m	M <sub>C</sub> N-m	C N	C <sub>0</sub> N	
31.2	5.5	M5×5	4.9	7.45	392	676	0.25
45	10.5	M5×4.5	4.9	11.1	392	676	0.37
45	10.5	M5×4.5	8.43	15.4	549	951	0.52
45	10.5	M5×4.5	15.4	22.1	794	1350	0.72

Note) \*M<sub>A</sub>, M<sub>B</sub> and M<sub>C</sub> each indicate the permissible moment per LM system, as shown in the figure above.

## Speed Controller

Fig.2 shows the shape of the speed controller.

Note) The speed controller is optional. (control method: meter out)

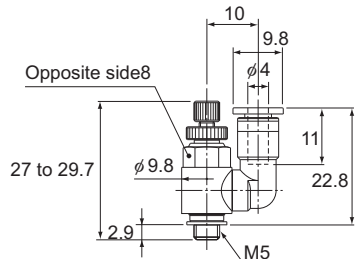

Fig.2 Shape of the Speed Controller  
(common to all model numbers)

## Dedicated Unit Base Model B

With Linear Ball Slide model LSC, a limit switch for detecting the stroke end can be mounted using a dedicated unit base (Fig.3). When fine positioning is required, a dedicated stopper can be mounted on the unit base to adjust the position. (excluding model LSC1015)

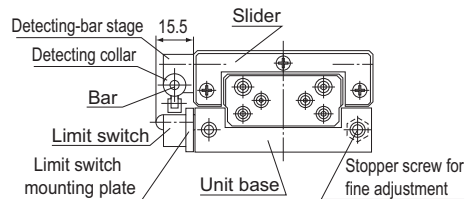
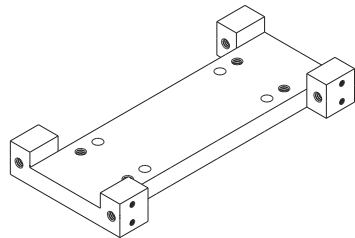
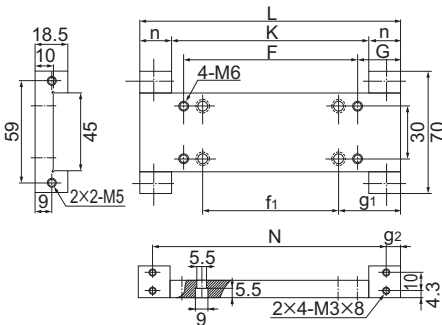

Fig.3 Unit Base and Limit Switch Installation



Unit: mm

Unit base Model B	Unit base dimensions									Mass kg
	Length L	F	G	f <sub>1</sub>	g <sub>1</sub>	K	n	N	g <sub>2</sub>	
LSC1515	80	40	21	23	29.5	56	12	68	6	0.12
LSC1530	110	60	25	40	35	74	18	94	8	0.16
LSC1550	150	100	25	78	36	114	18	134	8	0.21

## Limit Switch

The specifications of the limit switch are as follows.

<Limit switch specifications>

Type	D2VW-5L2A-1 (Omron)
Contact type	contact (1C contact)

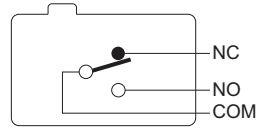

<Rated Specifications>

Type	Rated voltage (V)		Non-inductive load (A)				Inductive load (A)	
			Resistance load		Ramp load		Inductive load	
			Normally closed	Normally open	Normally closed	Normally open	Normally closed	Normally open
D2VW-5	AC	125	5		0.5		4	
		250	5		0.5		4	
	DC	30	5		3		4	
		125	0.4		0.1		0.4	

Note1) The above figures indicate the constant current.

Note2) Inductive load refers to power factor of 0.7 or greater (alternate current) and time constant of 7 ms or less (direct current).

Note3) Ramp load implies a rush current 10 times greater.

Note4) The above rated values apply when a test is conducted with the following conditions in accordance with JIS C 4505.

(1) Ambient temperature: 20°C ± 2°C

(2) Ambient humidity: 65% ± 5% RH

(3) Operating frequency: 30 times/min

Note) For applications under a minute load (5 to 24 VDC), a minute-load type is available. Contact THK for details.

## Model Number Coding

Model number configurations differ depending on the model features. Refer to the corresponding sample model number configuration.

[Linear Ball Slide]

- Models LSP, LS and LSC

**LS1027**

Model No.

- LSC with unit base

**LSC1515 B S L**

Model No.

With unit base

With external stopper

With limit switch

Note) Unit base, external stopper and limit switch are not available for model LSC1015.  
The speed controller is optional.

For accessories of LSC with a unit base, see "List of accessories for LSC with a unit base" (see **A9-17**).

- List of accessories for LSC with a unit base

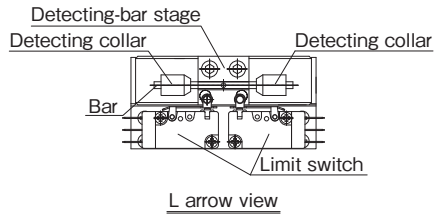
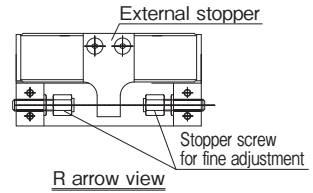
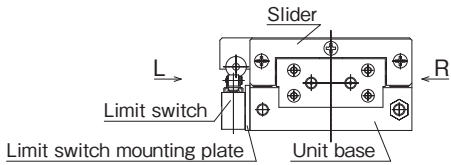

Model No.	Accessories
Model LSC1515 B	Unit base (x 1)
Model LSC1515 BS	Unit base (x 1), external stopper (x 1), stopper screw for fine adjustment (x 2)
Model LSC1515 BSL	Unit base (x 1), external stopper (x 1), stopper screw for fine adjustment (x 2), limit switch (x 2), detecting-bar stage (x 1), detecting collar (x 2), bar (x 1)

## Notes on Ordering

If you require a model LSC speed controller, contact THK.

## [Handling]

- (1) Disassembling components may cause dust to enter the system or degrade mounting accuracy of parts. Do not disassemble the product.
- (2) Dropping or hitting the Linear Ball Slide may damage it. Giving an impact to the product could also cause damage to its function even if the product looks intact.

## [Lubrication]

- (1) Apply lubricant before using the product.
- (2) Do not mix lubricants of different physical properties.
- (3) In locations exposed to constant vibrations or in special environments such as clean rooms, vacuum and low/high temperature, normal lubricants may not be used. Contact THK for details.
- (4) When planning to use a special lubricant, contact THK before using it.

## [Offset of the Cage]

The cage used to hold the balls may be offset due to machine vibration, inertia, impact, etc.

If the product is used under the following conditions, the cage is subject to being offset. In such cases, we recommend using model LSP or LSC.

- Vertical use
- Pneumatic cylinder drive
- Cam drive
- High speed crank drive
- Under a large moment load
- Application where the product is to be stopped by colliding the table against an external stopper.

## [Precautions on Use]

- (1) Entrance of foreign material may cause damage to the ball circulating component or functional loss. Prevent foreign material, such as dust or cutting chips, from entering the system.
- (2) If foreign material such as dust or cutting chips adheres to the product, replenish the lubricant after cleaning the product with pure white kerosene.
- (3) Contact THK if you desire to use the product at a temperature of 80°C or higher.
- (4) When using the product in locations exposed to constant vibrations or in special environments such as clean rooms, vacuum and low/high temperature, contact THK in advance.
- (5) The Linear Ball Slide is incorporated with a stopper mechanism that prevents the slider from coming off. If impact is given, the stopper may be damaged. Do not use this stopper as a mechanical stopper.

## [Storage]

When storing the Linear Ball Slide, enclose it in a package designated by THK and store it while avoiding high temperature, low temperature and high humidity.



# Linear Ball Slide

THK General Catalog

## B Support Book

<b>Features and Types</b> .....	B9-2
Features of the Linear Ball Slide .....	B9-2
• Structure and Features .....	B9-2
Types of the Linear Ball Slide .....	B9-4
• Types and Features .....	B9-4
<b>Point of Selection</b> .....	B9-5
Rated Load and Nominal Life .....	B9-5
<b>Model No.</b> .....	B9-7
• Model Number Coding .....	B9-7
• Notes on Ordering .....	B9-8
<b>Precautions on Use</b> .....	B9-9

## A Product Descriptions (Separate)

<b>Features and Types</b> .....	A9-2
Features of the Linear Ball Slide .....	A9-2
• Structure and Features .....	A9-2
Types of the Linear Ball Slide .....	A9-4
• Types and Features .....	A9-4
<b>Point of Selection</b> .....	A9-5
Rated Load and Nominal Life .....	A9-5
Accuracy Standards .....	A9-7
<b>Dimensional Drawing, Dimensional Table</b>	
Model LSP .....	A9-8
Model LS .....	A9-10
Model LSC .....	A9-12
• Speed Controller .....	A9-14
• Dedicated Unit Base Model B .....	A9-14
• Limit Switch .....	A9-15
<b>Model No.</b> .....	A9-16
• Model Number Coding .....	A9-16
• Notes on Ordering .....	A9-17
<b>Precautions on Use</b> .....	A9-18

## Features of the Linear Ball Slide

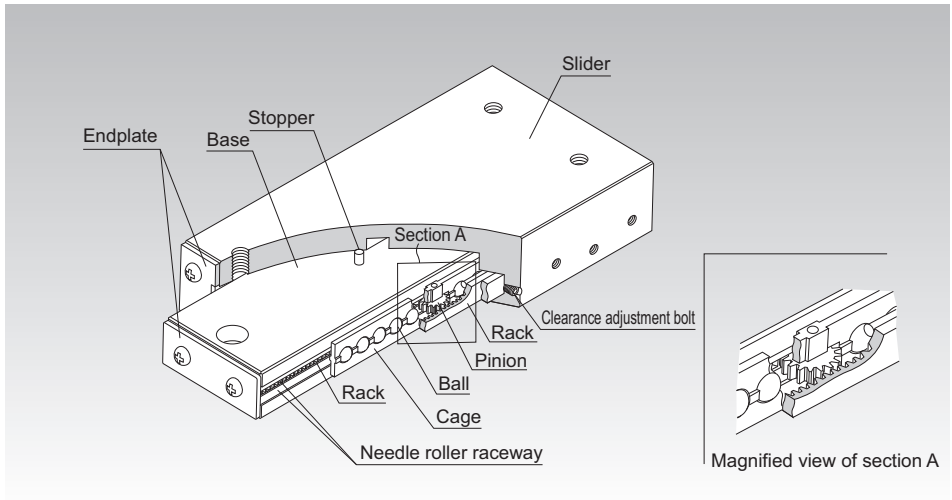

Fig.1 Structure of Linear Ball Slide Model LSP

### Structure and Features

The Linear Ball Slide is a highly corrosion resistant slide unit that has an extremely low friction coefficient because stainless steel balls roll on four stainless steel needle roller raceways that are hardened and ground.

In addition, model LSP has a pinion gear in the center and a rack on the base to prevent the cage from slipping.

A ball slide equipped with a cylinder model LSC has a cylinder for drive in the base to downsize the system and reduce the space and the weight.

Its components are all made of stainless steel, which is highly corrosion resistant. Furthermore, since its inertia is small, the slide system is highly responsive to high speed. By simply securing the Linear Ball Slide on the mounting surface, the user can easily achieve a linear guide mechanism. Thus, this slide system is optimal for locations requiring high accuracy, such as optic measuring machines, automatic recorders, small electronic-parts assembling machines, OA equipment and its peripherals.

#### [A Unit Type That Allows Easy Installation]

The clearance and motion of the slider is adjusted to the best state. Therefore, a highly accurate slide mechanism can be gained by simply mounting the unit on the flat-finished mounting surface.

#### [Lightweight and Compact]

A light aluminum alloy is used in the base and the slider to reduce the weight.

#### [Smooth Motion]

The balls and the raceway (needle roller raceway) are in point contact, which causes the smallest rolling loss, and the balls are evenly retained in the ball cage. This allows the slide system to perform rolling motion at a minimal coefficient of friction ( $\mu = 0.0006$  to  $0.0012$ ).

#### [Highly Corrosion Resistant]

The base and the slider are made of an aluminum alloy and their surfaces are treated with alumite (anodization processing), which is highly resistant to corrosion and wear.

The balls, needle roller raceways and screws are made of stainless steel, making the system highly corrosion resistant.

# Types of the Linear Ball Slide

## Types and Features

### Linear Ball Slide with a Rack Model LSP

Specification Table⇒ **A9-8**

With model LSP, the cage has a rack and pinion mechanism, thus to prevent the cage from slipping.

Also, since the cage does not slip even in vertical mount, this model is used in an even broader range of applications.

Note) Do not use the stopper as a mechanical stopper.

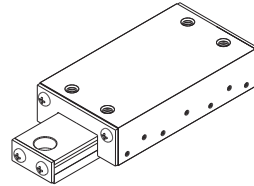

Model LSP

### Linear Ball Slide Model LS

Specification Table⇒ **A9-10**

Model LS is a unit-type linear system for finite motion that has a structure where balls are arranged between the base and the slider via a needle roller raceway.

It is incorporated with a stopper mechanism, thus to prevent damage deformation caused by collision between the cage and the endplate.

Note) Do not use the stopper as a mechanical stopper.

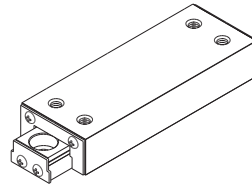

Model LS

### Linear Ball Slide with a Cylinder Model LSC

Specification Table⇒ **A9-12**

Model LSC contains an air cylinder for drive inside the base. Feeding air from the two ports on the side face of the base allows the slide to perform reciprocating motion. Since the cylinder is of double-acting type, horizontal traveling speed can be adjusted using the speed controller. The cylinder and the piston are made of a corrosion resistant aluminum alloy, and their surfaces are specially treated to increase wear resistance and durability. Additionally, the cage has a rack and pinion mechanism, thus enabling the cage to operate without slipping.

Air-feeding ports for piping are provided on one side face, ensuring a certain degree of operability and easy assembly even if the installation site has a limited space and is complex.

The table on the right shows the specifications of the air cylinder incorporated in model LSC.

Note) Do not use the stopper as a mechanical stopper.

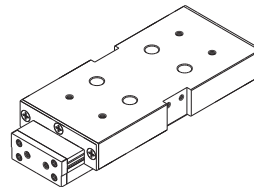

Model LSC

<Cylinder specifications>

Type of action	Double-acting
Fluid used	air (no lubrication)
Working pressure	100 kPa to 700 kPa (1 kgf/cm <sup>2</sup> to 7 kgf/cm <sup>2</sup> )
Stroke velocity	50 to 300mm/s

## Rated Load and Nominal Life

### [Rated Loads in All Directions]

The rated loads of models LS, LSP and LSC are identical in the vertical and horizontal directions.

### [Static Safety Factor $f_s$ ]

Linear Ball Slide models LS, LSP or LSC may receive an unexpected external force while it is stationary or operative due to the generation of an inertia caused by vibrations and impact or start and stop. It is necessary to consider a static safety factor against such a working load.

$$f_s = \frac{C_0}{P_c} \quad \text{or} \quad f_s = \frac{M_0}{M}$$

- $f_s$  : Static safety factor
- $C_0$  : Basic static load rating (N)
- $M_0$  : Static permissible moment (N-m)  
( $M_A$ ,  $M_B$  and  $M_C$ )
- $P_c$  : Calculated load (N)
- $M$  : Calculated moment (N-m)

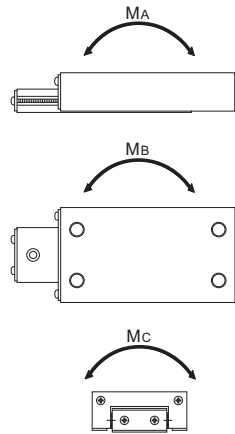

### ● Reference Value of Static Safety Factor

The static safety factors indicated in Table1 are the lower limits of reference values in the respective conditions.

Table1 Reference Value of Static Safety Factors ( $f_s$ )

Machine using the LM system	Load conditions	Lower limit of $f_s$
General industrial machinery	Without vibration or impact	1 to 1.3
	With vibration or impact	2 to 7

**[Nominal Life]**

The service life of the Linear Ball Slide is obtained using the following equation.

$$L = \left( \frac{1}{f_w} \cdot \frac{C}{P_c} \right)^3 \times 50$$

- L : Nominal life (km)  
(The total number of revolutions that 90% of a group of identical Linear Ball Slide units independently operating under the same conditions can achieve without showing flaking)
- C : Basic dynamic load rating (N)
- P<sub>c</sub> : Calculated load (N)
- f<sub>w</sub> : Load factor (see Table2)

**[Calculating the Service Life Time]**

When the nominal life (L) has been obtained, if the stroke length and the number of reciprocations per minute are constant, the service life time is obtained using the following equation.

$$L_h = \frac{L \times 10^6}{2 \times l_s \times n_1 \times 60}$$

- L<sub>h</sub> : Service life time (h)
- l<sub>s</sub> : Stroke length (mm)
- n<sub>1</sub> : Number of reciprocations per minute (min<sup>-1</sup>)

● **f<sub>w</sub>: Load Factor**

In general, reciprocating machines tend to involve vibrations or impact during operation. It is extremely difficult to accurately determine vibrations generated during high-speed operation and impact during frequent start and stop. Therefore, when the actual load applied on model VR or VB cannot be obtained, or when speed and vibrations have a significant influence, divide the basic load rating (C or C<sub>0</sub>), by the corresponding load factor in Table2 of empirically obtained data.

Table2 Load Factor (f<sub>w</sub>)

Vibrations/impact	Speed(V)	f <sub>w</sub>
Faint	Very low V ≤ 0.25m/s	1 to 1.2
Weak	Slow 0.25 < V ≤ 1m/s	1.2 to 1.5

---

### Model Number Coding

---

Model number configurations differ depending on the model features. Refer to the corresponding sample model number configuration.

[Linear Ball Slide]

- Models LSP, LS and LSC
- 

**LS1027**

Model No.

---

---

- LSC with unit base

**LSC1515 B S L**

Model No.

With unit base

With external stopper

With limit switch

---

Note) Unit base, external stopper and limit switch are not available for model LSC1015.  
The speed controller is optional.

For accessories of LSC with a unit base, see "List of accessories for LSC with a unit base" (see [B9-8](#)).

---

- List of accessories for LSC with a unit base

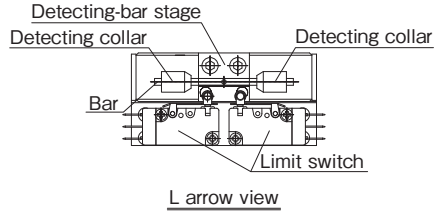
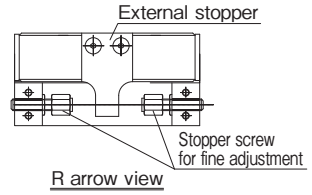
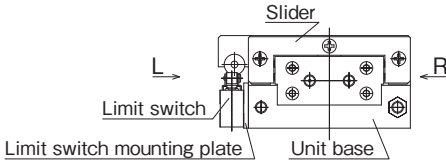

Model No.	Accessories
Model LSC1515 B	Unit base (x 1)
Model LSC1515 BS	Unit base (x 1), external stopper (x 1), stopper screw for fine adjustment (x 2)
Model LSC1515 BSL	Unit base (x 1), external stopper (x 1), stopper screw for fine adjustment (x 2), limit switch (x 2), detecting-bar stage (x 1), detecting collar (x 2), bar (x 1)

## Notes on Ordering

If you require a model LSC speed controller, contact THK.

## [Handling]

- (1) Disassembling components may cause dust to enter the system or degrade mounting accuracy of parts. Do not disassemble the product.
- (2) Dropping or hitting the Linear Ball Slide may damage it. Giving an impact to the product could also cause damage to its function even if the product looks intact.

## [Lubrication]

- (1) Apply lubricant before using the product.
- (2) Do not mix lubricants of different physical properties.
- (3) In locations exposed to constant vibrations or in special environments such as clean rooms, vacuum and low/high temperature, normal lubricants may not be used. Contact THK for details.
- (4) When planning to use a special lubricant, contact THK before using it.

## [Installation]

For the screw for fixing the base of the Linear Ball Slide, use a hexagonal-socket-head type bolt (JIS B 1176). For the models shown in the Table1, we recommend using the indicated screws.

Table1 Base fixing screw

Model No.	Type	Nominal name of screw
LS 827	Cross-recessed pan head screw	M2
LS 852		
LS 877		
LS 1050	Low-head, small-diameter bolt *	M3

\* Cross-recessed pan head screw JIS B 1111

\* Low-head, small-diameter bolts are not defined in the JIS standards. Select an appropriate off-the-shelf bolt from the dimensional table.

## [Offset of the Cage]

The cage used to hold the balls may be offset due to machine vibration, inertia, impact, etc.

If the product is used under the following conditions, the cage is subject to being offset. In such cases, we recommend using model LSP or LSC.

- Vertical use
- Pneumatic cylinder drive
- Cam drive
- High speed crank drive
- Under a large moment load
- Application where the product is to be stopped by colliding the table against an external stopper.

#### [Precautions on Use]

- (1) Entrance of foreign material may cause damage to the ball circulating component or functional loss. Prevent foreign material, such as dust or cutting chips, from entering the system.
- (2) If foreign material such as dust or cutting chips adheres to the product, replenish the lubricant after cleaning the product with pure white kerosene.
- (3) Contact THK if you desire to use the product at a temperature of 80°C or higher.
- (4) When using the product in locations exposed to constant vibrations or in special environments such as clean rooms, vacuum and low/high temperature, contact THK in advance.
- (5) The Linear Ball Slide is incorporated with a stopper mechanism that prevents the slider from coming off. If impact is given, the stopper may be damaged. Do not use this stopper as a mechanical stopper.

#### [Storage]

When storing the Linear Ball Slide, enclose it in a package designated by THK and store it while avoiding high temperature, low temperature and high humidity.